

Wireless. Fast. Accurate.



AXIS4000

Electronic Wheel Alignment

Camera Radio System

PC-based camera radio system.
The „Technical Revolution“
in mobile, electronic wheel alignment
for almost all types of commercial vehicles!

A PRODUCT OF



HAWEKA[®]

AXIS4000 from HAWEKA – the new generation of portable



AXIS

Electronic Wheel Alignment

- Fast measurement of total and single toe, steering gear middle position, caster, camber, KPI, thrust angle, maximum steering turn, as well as out of squareness and offset of the axles.
- Measurement takes place in an „as driven position“ – there is no need to lift up the vehicle.
- Different designs of magnetic feet ensure fast fitting to steel rims.



The product

AXIS4000 Computer-based wheel alignment system for commercial vehicles

The **AXIS4000** wheel alignment system is a new and innovative development from HAWEKA. This top-of-the-range product is the culmination of many years of experience in the field of portable wheel alignment.

This high-quality wheel alignment system enables realtime, highly accurate and fast measurements to be made.

The key factors that led to HAWEKA's decision to continue with the development of this measuring process were the high global demand for vehicle wheel alignment – combined with flexibility and accuracy of the measuring technology.

The result is **AXIS4000**, a wheel alignment system that meets the standards of car wheel alignment systems, in terms of ease of handling and measuring accuracy.



Readings recorded by radio transmission

A PC or Notebook is needed to record the readings. USB connection to receiver unit.

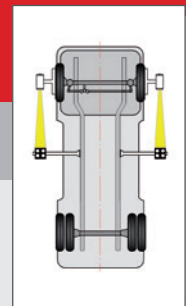

Fast fixing of the magnetic scales for setting up the **AXIS4000** wheel alignment system.

The measurement can begin once the cameras with alignment clamps have been fitted to the vehicle and the scales have been aligned to the vehicle using the software.

on-site wheel alignment systems for commercial vehicles.

4000

Camera Radio System

- The patented ProClamp clamping device with grapplers is ideal for aluminium rims.
- 360° rotating camera measuring heads guarantee instantaneous recording of actual data.
- The adjustment is immediately displayed on the monitor.
- The printout shows the „before“ and „after“ readings and setting values.
- The readings are recorded by radio transmission directly onto the printout.

Use

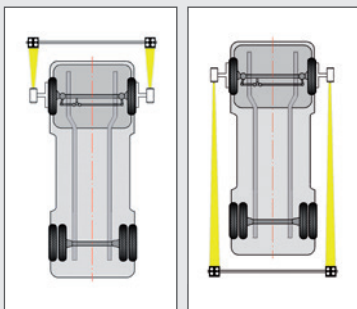

Simply moving the camera records all of the actual data and transmits it directly to the program.



Applications

For lorries and buses

The use of camera technology significantly simplifies wheel alignment and adjustments to these vehicles can be carried out speedily.



Upgrade set for wheel alignment on trailers

With additional adapters, toe, caster, offset and out of squareness can be quickly and accurately aligned.



For transporters

Specially cushioned „softline“ feet mean that transporter wheels can also be simply and easily aligned using this system.



For vehicles with multiple steering axles

Even vehicles with double steering axles can be aligned quickly simply with two additional turn plates.



AXIS4000 - convenient and easy to use

Fast input of vehicle data

Following the simple selection of the vehicle to be aligned, all of the relevant vehicle data can be quickly and conveniently selected – the dimensions of the rim can, for example, be entered individually.

The **AXIS4000** can thus be used to align almost all types of commercial vehicle right up to small transporters.

Simple set-up of the measuring scales

The preparation needed to align the wheels of a vehicle is clearly explained to the user by means of a simple and clear graphic display.

Clear recording of readings

The information obtained is available to the user while making the adjustments, either in digital or analog format, in a large and easily understood display.

Graphic commands

The operator is led through the individual stages thanks to the well laid-out menu structure and clear instructions. The readings are displayed instantaneously for each step.

Clear menu navigation

The possible measurement processes for each vehicle axle are displayed on selection buttons.

The readings are listed separately for each vehicle axle. This axle-specific display of the readings enables the user to make fast adjustments.

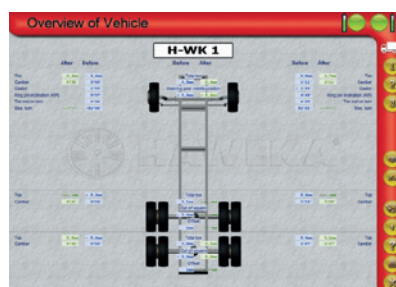
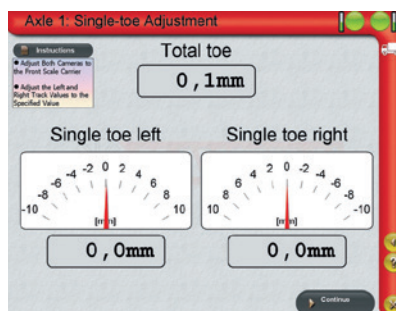
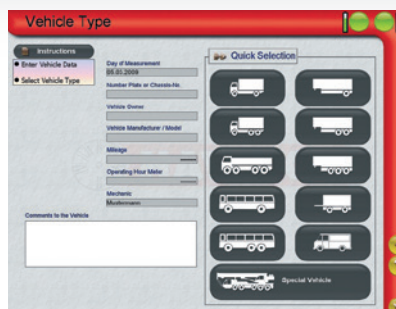

Clearly arranged data

Well laid-out overview of the readings for all vehicle axles in one display.

Printout / Overview

The overview shows the individual readings for each axle. This provides a clear comparison between starting and finishing readings. The readings can then be printed in a printout.

Technical data

	Measuring range	Accuracy of measurements
Toe measurement	± 5 degrees	± 0° 05'
Camber measurement	-15 degrees to +15 degrees	± 0° 05'
Castor	-5 degrees to +18 degrees	± 0° 05'
KPI	-10 degrees to +20 degrees	± 0° 15'
Max. steering turn	± 70 degrees	± 0° 20'
Operating time with fully charged batteries		> 10 h
Radio module	Frequency range 433,05 to 434,79 Mhz	
Number of channels	10	
Transmission power	10 mW	
Charger	Operating voltage 100 – 240 V	

System requirements for AXIS4000

Required operating system:
Windows Vista, Windows 7, Windows 8.1

Minimum hardware requirements:

Processor: Pentium IV- AMD Athlon 1 GHz, RAM: 512 MB (Windows XP) / 1024 MB (Windows Vista, Windows 7), available hard disk space: 100 MB, graphics: resolution 1024 x 768 pixel / high colour, sound card, port: USB 1.1, CD-ROM drive

Recommended:

Processor: Pentium or AMD with 1,6 GHz or larger, RAM: 1024 MB, graphics card with AMD (ATI) or NVIDIA chipset greater than 16 MB, resolution 1280 x 1024 pixel / true colour, WLAN (option for portable handheld model), printer

Optional accessories



A stable trolley ensures that all components of the **AXIS4000** can be kept conveniently and securely and provides space for a printer, which can be positioned in a cupboard.